

THIS DRAWING IS UNPUBLISHED. RELEASED FOR PUBLICATION
 © COPYRIGHT - By - ALL RIGHTS RESERVED.

LOC	DIST	REVISIONS					
		P	LTR	DESCRIPTION	DATE	DWN	APVD
G	14		F2	REVISED PER ECO-11-004917	11MAR11	RK	HMR

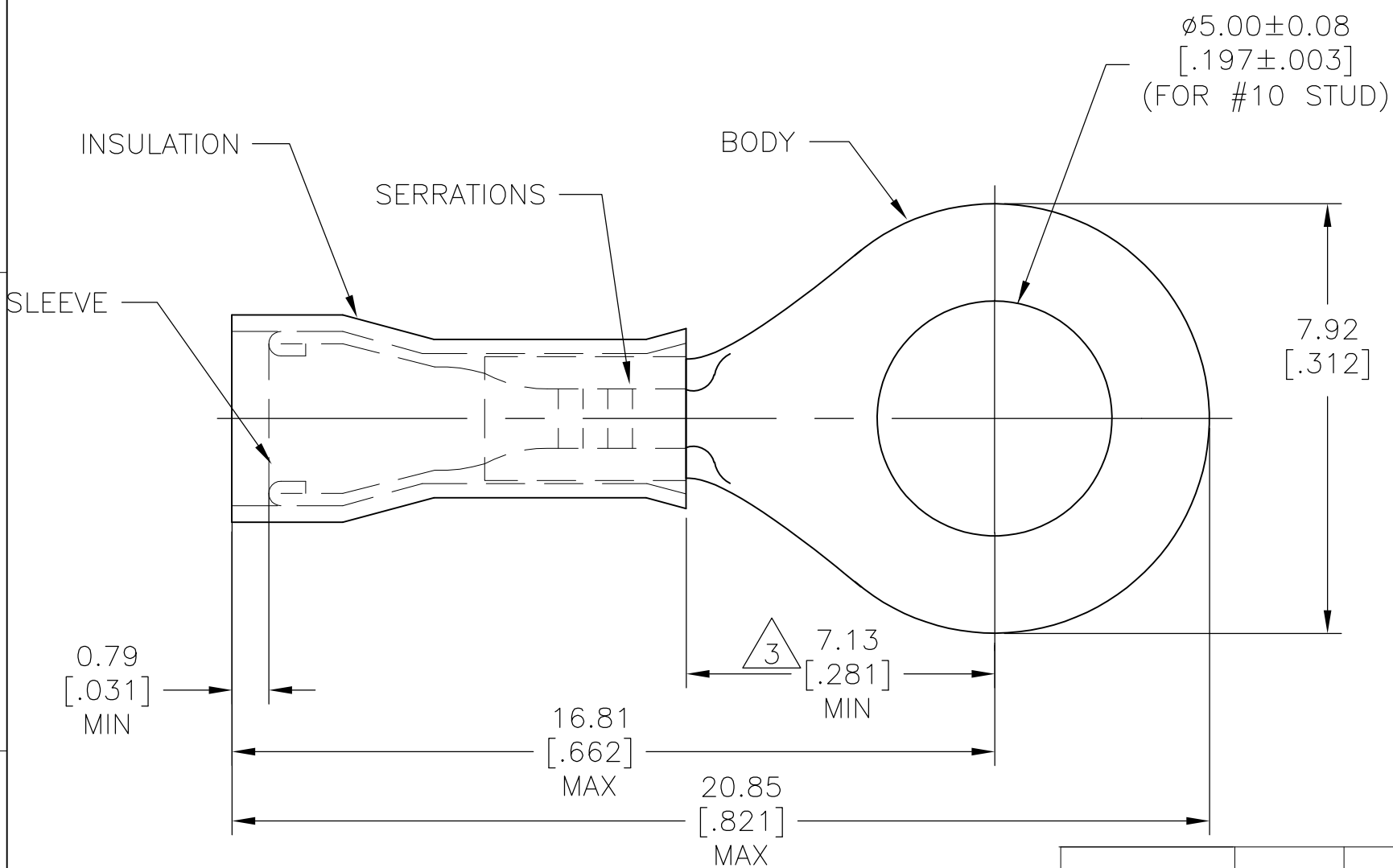

- 1 FOR 1.02 [$.040$] TO 2.54 [$.100$] WIRE INSULATION DIA
- 2 TONGUE MATERIAL THK = 0.58 ± 0.05 [$.023 \pm .002$]
- △3 APPLIES FROM THE METAL EDGE OF THE BARREL TO THE CENTER OF THE STUD
- △4 SUPERCEDED BY 323990

△4	OBSOLETE	5000	2-323990-2 ON TAPE	BODY & SLEEVE: COPPER (ASTM-B152) TIN PL (ASTM-B545) INSULATION: BLACK NYLON (ASTM-D4066) TYPE 1	2-323990-3
△4	OBSOLETE	1000	LOOSE PC		2-323990-2
△4	OBSOLETE	5000	323990 ON TAPE	BODY & SLEEVE: COPPER (ASTM-B152) TIN PL (ASTM-B545) INSULATION: NATURAL NYLON (ASTM-D4066) TYPE 1	2-323990-1
		1000	LOOSE PC		323990
		QTY	PACKAGE TYPE	MATERIAL & FINISH	PART NO

THIS DRAWING IS A CONTROLLED DOCUMENT.		DWN R.GRZYBOWSKI 9NOV2009	STE TE Connectivity		
DIMENSIONS: mm [INCHES]		CHK TOM MICHIELUTTI 9NOV2009			
TOLERANCES UNLESS OTHERWISE SPECIFIED:		APVD M.PERCHERKE 9NOV2009	NAME		
0 PLC ± -		PRODUCT SPEC	WIRE TERMINAL		
1 PLC ± -		APPLICATION SPEC	PIDG - RING TONGUE		
2 PLC ± -		WEIGHT	WIRE SIZE: 24-20		
3 PLC ± 0.20 [.008]			SIZE	CAGE CODE	DRAWING NO
4 PLC ± -			A3	00779	C-323990
ANGLES ± 0° 30'			RESTRICTED TO		
MATERIAL SEE TABLE	FINISH SEE TABLE	CUSTOMER DRAWING		SCALE 8:1	SHEET 1 OF 1
				REV F2	